

# marantz

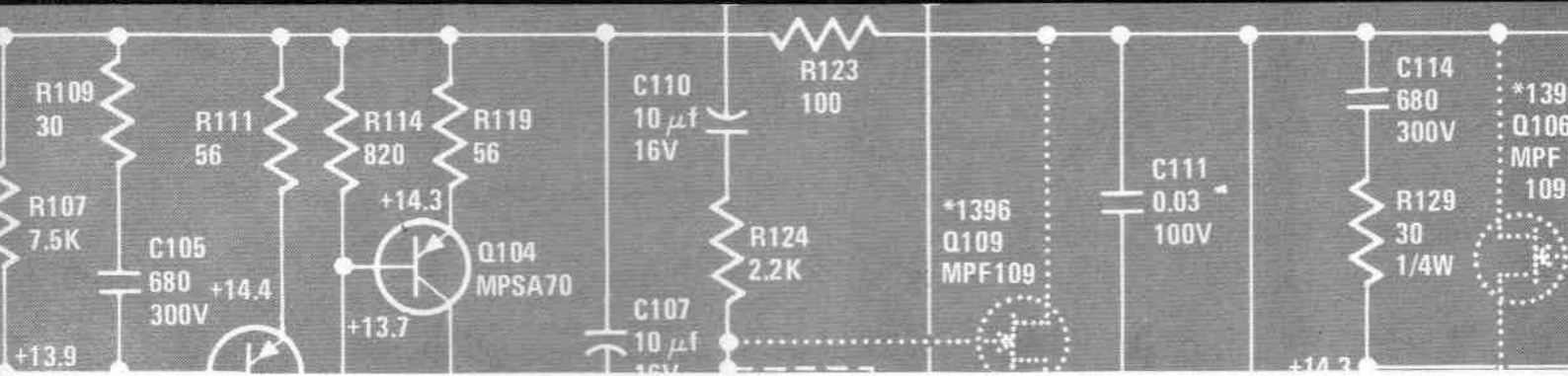

## model thirty-three

## SERVICE MANUAL

# 33

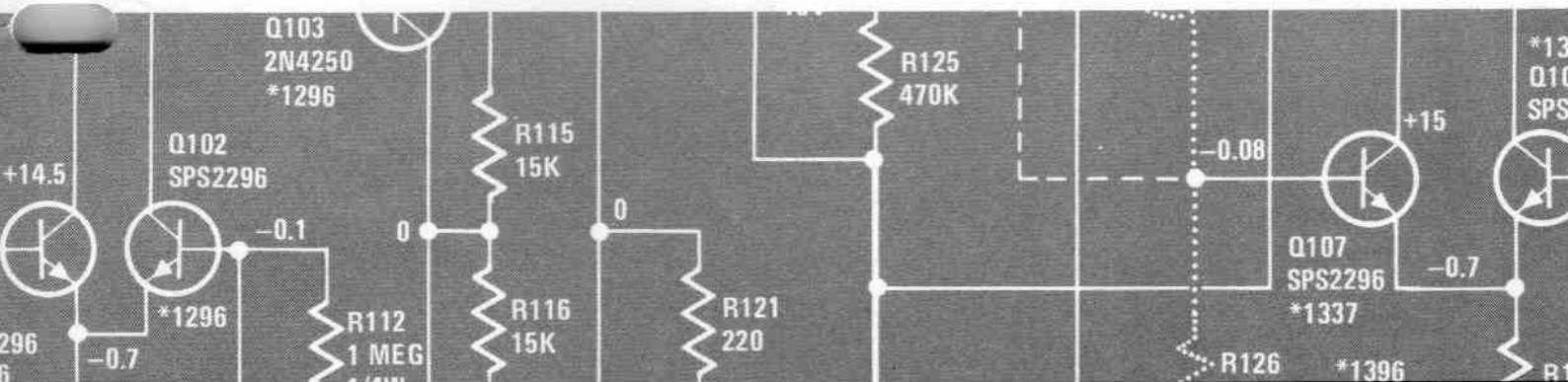

## *Stereo Console*

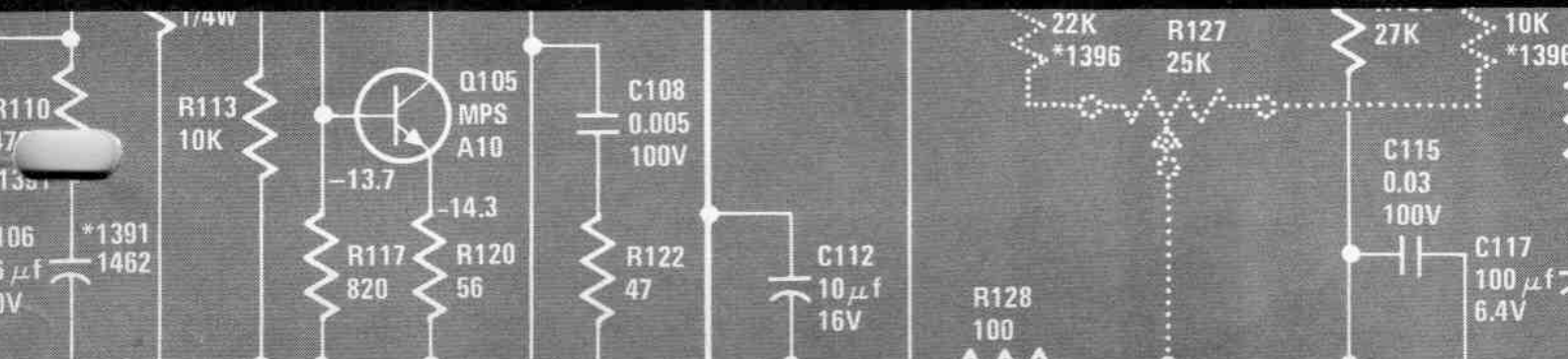

# TABLE OF CONTENTS

<b>SECTION</b>	<b>PAGE</b>
Introduction	1
Circuit Description	1
240-Volt Conversion	4
Technical Specifications	5
Performance Verification	7
Trouble Analysis	10
Parts List	11
Component Layout Diagram	15
Schematic	18
Service Notes	24
Change Record	26

# LIST OF ILLUSTRATIONS

<b>FIGURE</b>		<b>PAGE</b>
1.	Tone Control Response Curves	2
2.	Filter Response Curves	3
3.	Band Pass Filter Schematic	4
4.	AC Power Control Box Simplified Schematic	6
5.	Test Equipment Set-up	7
6.	NAB and RIAA Equalization Curves	9
7.	Preamplifier Board Component Assembly Diagram Revision 1	15
8.	Preamplifier Board Component Assembly Diagram Revision 2	17
9.	Preamplifier Circuit and Switching Schematic	18
10.	Power Supply Board Component Assembly Diagram	20
11.	Power Supply Circuit Schematic	21
12.	Filter/Center Channel Component Assembly Diagram	22
13.	Filter/Center Channel Circuit Schematic	23

<b>TABLE</b>		<b>PAGE</b>
1.	Test Equipment Required for Servicing	6

# INTRODUCTION

This service manual is intended for use by authorized warranty stations. The manual contains service information for the Marantz Model 33 Stereophonic Console, manufactured by the Marantz Company, a subsidiary of Superscope Incorporated, Sun Valley, California 91352.

Adjustment, maintenance, and troubleshooting information listed herein should be attempted only by the experienced technician, one knowledgeable in solid state theory and the use of test equipment. All instructions should be read carefully and understood fully before proceeding with any service.

Symptoms (and their remedies) listed in the troubleshooting section are those which might occur in some units. As the Marantz Company becomes aware of other field problems, supplementary service bulletins will be issued to all stations. To improve this service, all problems (and their solutions) not covered in this service manual should be brought to the attention of the National Service Manager at our Sun Valley location.

## CIRCUIT DESCRIPTION

The Model 33 comprises a LOW LEVEL AMPLIFIER, a TONE AMPLIFIER, a X-10 AMPLIFIER, a HEADPHONE AMPLIFIER, a HIGH AND LOW FILTER CIRCUIT, and an OUTPUT AMPLIFIER which operate independently for each channel (except for Tone Controls, both channels are simultaneously affected by the Front Panel controls and jacks). The POWER SUPPLY CIRCUIT supplies the required power to each channel from a common source. In the following circuit description, only CHANNEL A will be discussed; CHANNEL B is functionally identical.

## LOW-LEVEL AMPLIFIER

Program source signals from the 6 jacks (3 low level and 3 high level) on the rear panel are supplied to the SELECTOR switch. The 3 low-level inputs are applied to the low-level amplifier. A section of the SELECTOR switch selects the appropriate (NAB, RIAA) equalization network. The low-level amplifier comprises a single-ended differential amplifier (Q101, Q102), an inverter (Q103), and a complementary-symmetry pair (Q105, Q106). This amplifier provides a gain of 40 dB. The output of the low-level amplifier is applied to another section of the SELECTOR switch.

This section of the SELECTOR switch applied either the output of the low-level amplifier or one of the high-level inputs to the TAPE MONITOR switch.

The TAPE MONITOR switch applies either the TAPE IN (or DUBBING IN) or program source signals to the mode switch. The DUBBING IN jack contains a built-in switch which disconnects the TAPE IN signals when a plug is inserted into the jack. The signal is applied, in turn, to the MODE switch; BALANCE control and SCOPE OUT jacks; and VOLUME control.

The MODE switch applies the CHANNEL B signal simultaneously to both amplifier channels when in the "B" position; the CHANNEL A signal simultaneously to both amplifier channels when in the "A" position; the CHANNEL A signal to the CHANNEL A amplifier and the CHANNEL B signal to the CHANNEL B amplifier when in the "STEREO" position; the CHANNEL A signal to the CHANNEL B amplifier and the CHANNEL B signal to the CHANNEL A amplifier when in the "STEREO REVERSE" position; or both CHANNEL A and CHANNEL B signals simultaneously to both amplifier channels when in the "A&B" position.

The BALANCE control is a full range graphic slide-type control that permits full attenuation of either channel without affecting the other channel. The output of this control is applied to the VOLUME control and the HEADPHONE level control. The VOLUME control is a precision tracking graphic slide-type control which maintains the stereo balance dictated by the BALANCE control (within 1 dB) from maximum to -65 dB below maximum. The output of the VOLUME control is applied to the X10 amplifier.

## X-10 AMPLIFIER

The X10 amplifier (Revision 1) comprises an FET-driven single-ended differential amplifier (Q106, Q107, Q108, Q109) followed by an inverter (Q110) and a complementary symmetry pair (Q111, Q112). The X10 amplifier (Revision 2) comprises a single-ended differential amplifier (Q107, Q108) followed by an inverter (Q110) and a complementary symmetry pair (Q111, Q112). The X10 amplifier provides a gain of 20 dB. The output of the X10 amplifier is applied to the TONE CONTROL switch and the tone amplifier.

With the TONE CONTROL switch set to OUT, the output of the X10 amplifier is applied directly to the DUBBING OUT jack and the filter center channel board.

## TONE AMPLIFIER

The output of the X10 amplifier is applied to the unity gain tone amplifier through a coupling capacitor (C121). The tone amplifier comprises a single-ended differential amplifier (Q113, Q114), an inverter (Q115) and a complementary-symmetry pair (Q116, Q117). The frequency response of the amplifier is adjusted by the BASS (R18, R20) and TREBLE (R19, R21) controls as indicated in Figure 1.

With the TONE CONTROL switch set to LOUDNESS, audio corrections approximately equal to the Fletcher-Munson loudness contour are inserted via a tap at the volume control.

With the TONE CONTROL switch set to IN or LOUDNESS, the output of the tone amplifier is applied to the DUBBING OUT jacks and the filter/center channel board.

## HEADPHONE AMPLIFIER

Signals from the BALANCE control are applied to the HEADPHONE level control (R12). This control adjusts the level of the signal applied to the headphone amplifier. The headphone amplifier comprises a series pair (Q118, Q119) and a constant-current source (Q120). This amplifier provides a gain of 22.3 dB and has a "flat" frequency response.

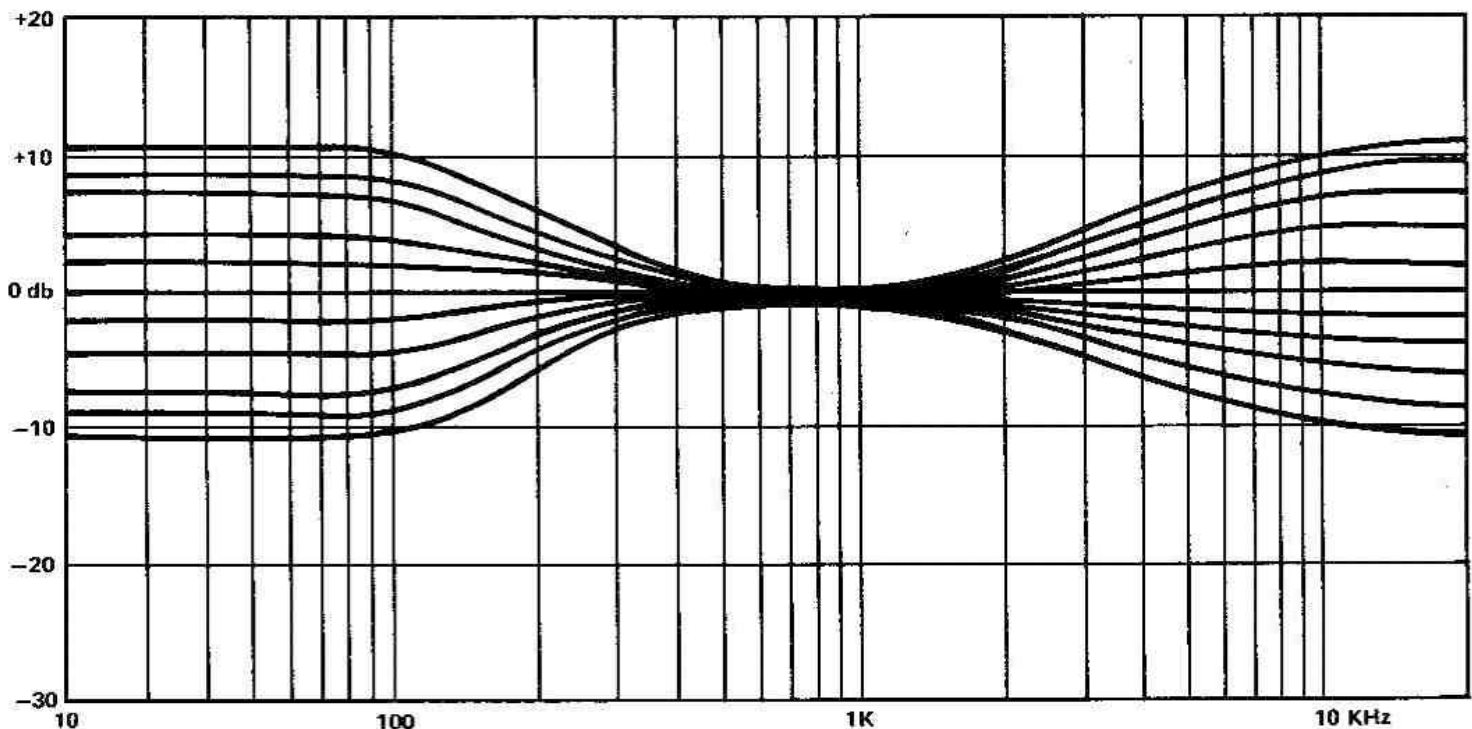

Figure 1. Tone Control Response Curves

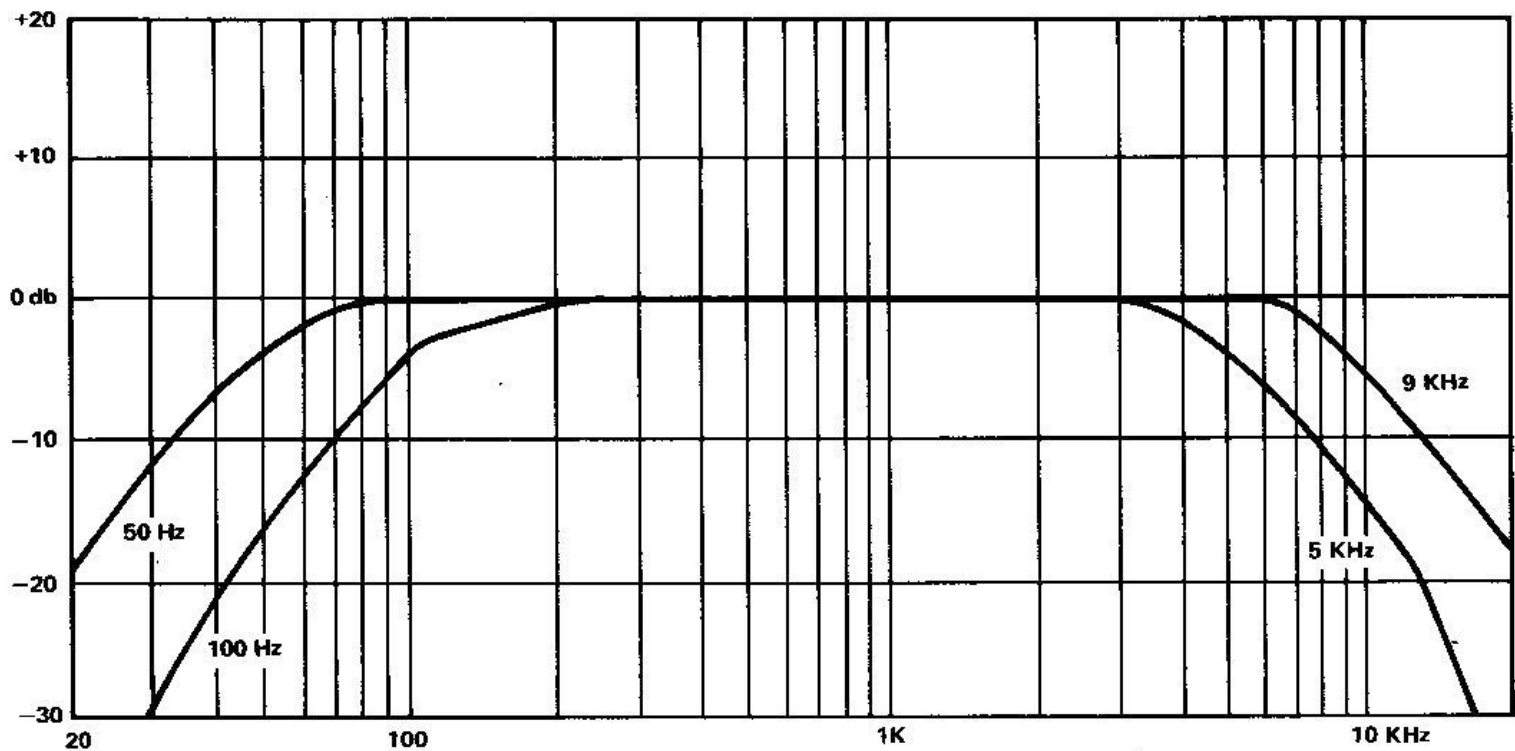

Figure 2. Filter Response Curves

## HIGH and LOW FILTER

The three-position HIGH and LOW filter switches each select between two two-pole filters thus providing true double time constant functions when placed in their active positions.

When set to OUT, the filter switches bypass the filters and apply the X10 or tone amplifier signal to the unity gain output buffer amplifier.

## OUTPUT AMPLIFIER

The output amplifier comprises a series pair (Q201, Q202). The output of this amplifier is applied to the PRE-AMP OUT jacks and through a running network to the CENTER CHANNEL VOLUME CONTROL. This control adjusts the level of the signal applied to the center channel amplifier. This amplifier comprises a series pair (Q205, Q206). The output of the center channel amplifier is applied to the CENTER CHANNEL OUTPUT jack.

## POWER SUPPLY

The following discussion is based on the positive supply only. The negative supply operates in an identical manner.

AC voltage from T1 is rectified by the diode bridge comprising CR301 through CR304. The resulting DC voltage is amplified by a Darlington pair (Q302, Q303).

This pair is regulated by a constant-current source (Q301). Further regulation is applied by a differential amplifier (Q305, Q306) which samples the output voltage. The voltage reference for Q305 is Zener diode CR305. The adjustable voltage reference for Q306 is potentiometer R309. Overcurrent protection is provided by Q304. Excessive current causes an increased voltage drop across R306, causing Q304 to turn on and ground the input to Q302. Overload recovery is instantaneous.

## 240-VAC CONVERSION

To convert the Model 33 to 240-volt operation, perform the following steps:

1. Remove top and bottom covers.
2. Using the 240-volt AC conversion kit, part number 105-1003-1, attach the standoff terminal, part number 359-1002, to the chassis (in the #6 hole next to the fuseholder) with the #6-32 x 1/8 screw supplied.
3. Unsolder the gray wire from the fuseholder. Unsolder the black wire from J5 pin 2.
4. Re-route the black wire to the compartment containing the standoff terminal.
5. Solder the gray and black wire to the standoff terminal.
6. Replace the top and bottom covers.
7. Replace the 1/4 amp, 250V fuse in the unit with the 1/8 amp, 250V fuse, part number 451-1007, supplied with the conversion kit.
8. Remove the protective backing from the caution label, part number 180-1008, and place it on the top cover.

The Model 33 is now ready for 240-volt operation.

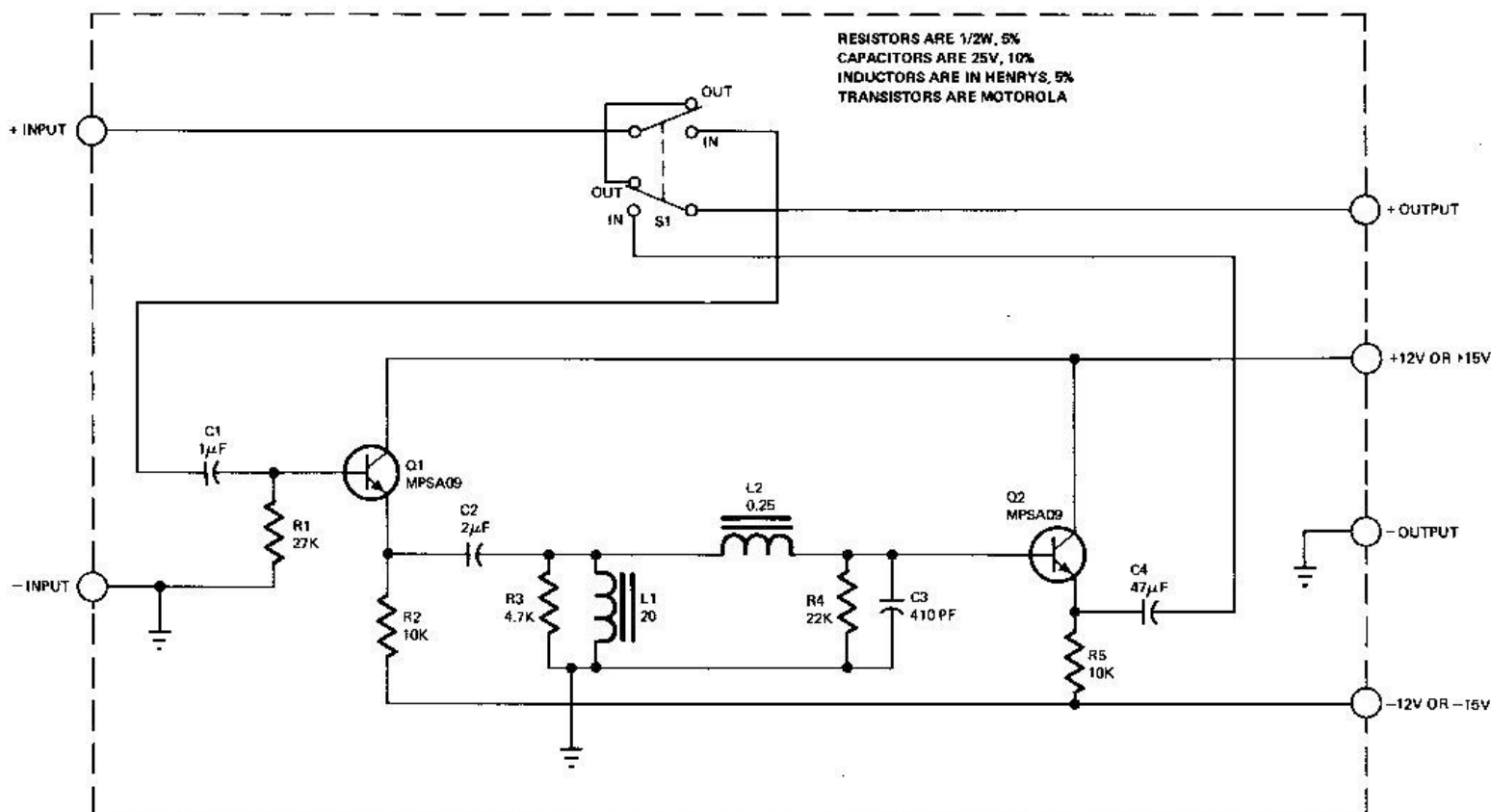

Figure 3. Band Pass Filter Schematic

# TECHNICAL SPECIFICATIONS

## GAIN

Phono to main output . . . . .	60 dB
Phono to recording output . . . . .	40 dB
High level to main output . . . . .	20 dB

## TOTAL HARMONIC DISTORTION

At 3 volts output — 20 Hz to 20 KHz . . . . .	Less than 0.02%
---	-----------------

## INTERMODULATION DISTORTION

At 3 volts output . . . . .	Less than 0.02%
-----------------------------	-----------------

## FREQUENCY RESPONSE

5 Hz to 100 KHz . . . . .	+0, -1 dB
20 Hz to 20 KHz . . . . .	-0.25 dB

## TOTAL NOISE (equivalent input)

20 Hz to 20 KHz (phono input loaded and shielded) . . . . .	1.0 $\mu$ V
---	-------------

## DYNAMIC RANGE (S/N range)

Phono Input (equivalent noise). . . . .	118 dB above 1.0 $\mu$ V
---	--------------------------

## CHANNEL SEPARATION (20 Hz to 20 KHz).

58 dB

## INPUT SENSITIVITY

Phono — for 1V output . . . . .	1 mV
High level — for 1V output . . . . .	100 mV

## INPUT IMPEDANCE

Phono . . . . .	47K ohms
Tape Head . . . . .	100K ohms
High Level . . . . .	50K ohms

## VOLUME TRACKING (max. to -65 dB from max.)

within 1 dB

## OUTPUT LEVEL AND IMPEDANCE

Main. . . . .	10 volts, 200 ohms
Center Channel . . . . .	5 volts, 200 ohms
Tape Recorder . . . . .	10 volts, 200 ohms
Headphones . . . . .	10 volts, 300 ohms

## TONE CONTROLS (Switch Defeatable)

Treble . . . . .	$\pm$ 10 dB at 10 KHz
Bass . . . . .	$\pm$ 10 dB at 100 Hz

## FILTERS

High (5 KHz and 9 KHz) . . . . .	12 dB per octave
Low (50 Hz and 100 Hz) . . . . .	12 dB per octave

## NUMBER OF SEMI-CONDUCTORS

Revision 1. . . . .	6 F.E.T's, 52 Transistors, 8 Diodes
Revision 2 . . . . .	2 F.E.T's, 52 Transistors, 8 Diodes

## POWER REQUIREMENTS

105 to 125 volts AC, 50/60 Hz, 10 Watts

## DIMENSIONS

5-3/4" High, 15-3/4" Wide, 8-3/4" Deep

## WEIGHT

Unit . . . . .	12 lbs.
Shipping . . . . .	16 lbs.



# TEST EQUIPMENT REQUIRED FOR SERVICING

Table 1 lists the test equipment required for servicing the Model 33 Stereo Console. The wattmeter ac voltmeter, and variac may be assembled as a test fixture as shown schematically in Figure 4.

Item	Manufacturer and Model Number (or equivalent)	Use
Distortion Analyzer	Hewlett Packard, Model 333A or 331A	Measures distortion and voltage.
Audio Oscillator	Weston Model CVO-100P (Note: Less than 0.01 per cent residual distortion is required.)	Sine wave signal source.
Oscilloscope	Tektronix Model 503, Data Model 555	Waveform analysis and trouble shooting.
VTVM	RCA Senior Volt-Ohmyst Model MV-98C.	Voltage and resistance measurements.
AC Wattmeter	Simpson Model 390	Monitors primary power consumption.
Line Voltmeter (0 to 150 VAC)	Commercial Grade	Monitors primary power potential.
Variable Autotransformer (0-140 vac, 10 Amps)	Powerstat Model 116B	Adjust level of primary power.
Shorting Plug	Use phono plug with 600 ohms across center pin and shell	Shorts inputs to eliminate noise pick up.
Bandpass Filter	Fabricate in accordance with Figure 3	Eliminates broadband noise when checking noise spec.

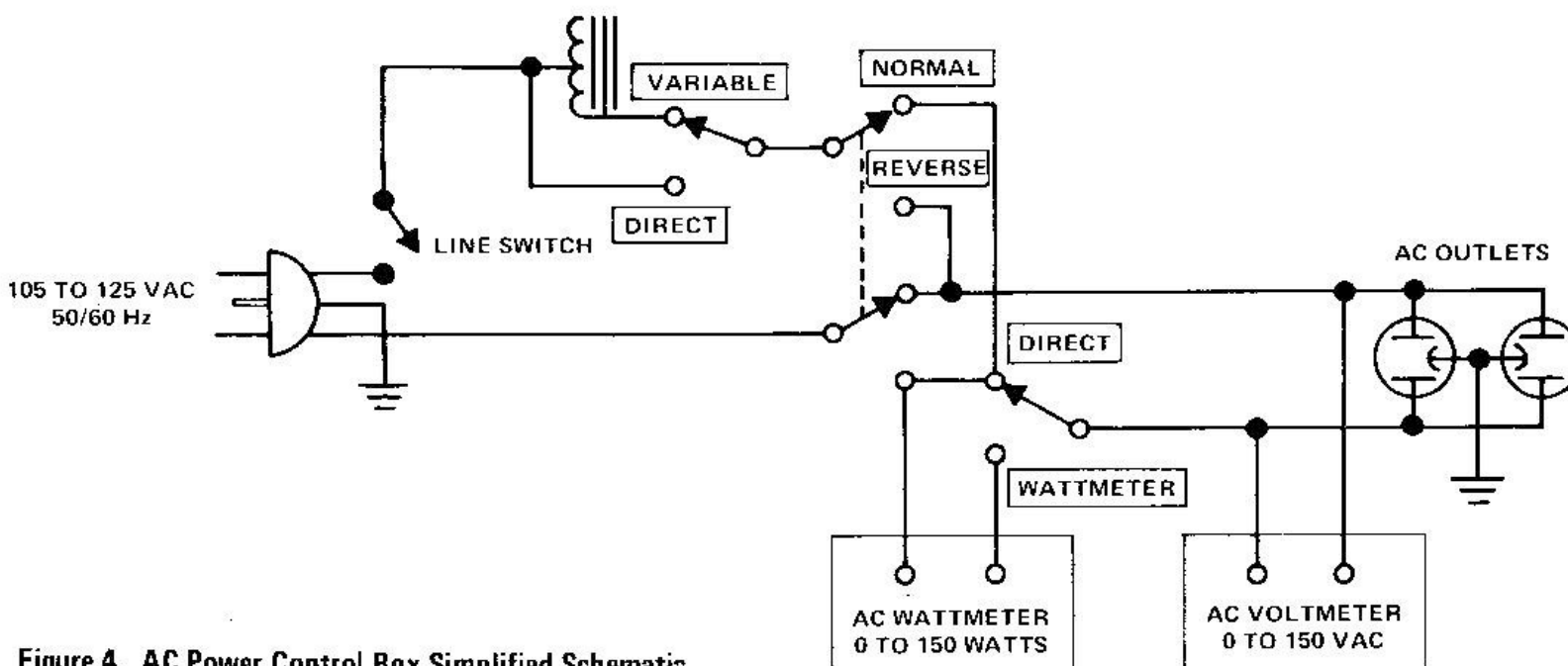

Figure 4. AC Power Control Box Simplified Schematic

# PERFORMANCE VERIFICATION

## TEST PROCEDURE

### INITIAL SET-UP

Connect test equipment as shown in Figure 5. The following procedure is to be followed each time the equipment is tested and after every repair.

### INITIAL SWITCH POSITIONS

Line Switch	Off
Variac	0 Volts
Bandpass	Out
MODEL 33	
Selector	Aux 1
Mode	Stereo
Tone Control	In (Bass and Treble: 0 dB)
Tape Monitor	Out
Volume	Maximum
Balance	Centered
Filters	Out
Headphone	Maximum
Power	Off
Center Channel Volume	Maximum

### A. Power Consumption

1. Set line switch to ON.
2. Set Model 33 POWER switch to ON.
3. Slowly increase variac setting until line voltmeter reads 120V.
4. AC wattmeter should indicate less than 5 watts. If wattmeter indicates more than 5 watts, stop test and proceed to Trouble Analysis section of this manual.

### B. Functional

1. Using audio oscillator, oscilloscope, and voltmeter section of distortion analyzer perform functional check of all controls and jacks.
2. Verify normal operation before proceeding with remaining tests.

NOTE: The following tests should be performed for both channels.

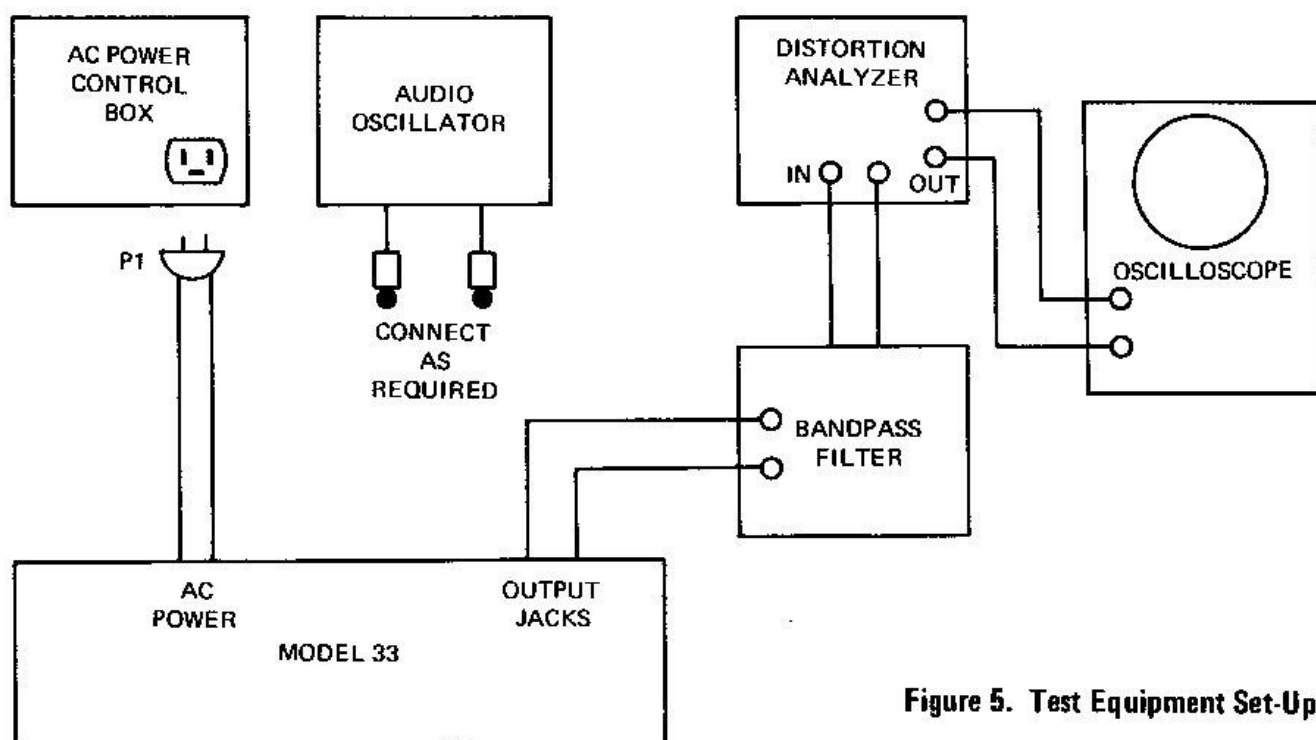

Figure 5. Test Equipment Set-Up.

### C. Hum and Noise

1. Set SELECTOR switch to PHONO 1.
2. Insert shorting plugs in PHONO 1 jacks.
3. Set bandpass switch to IN.
4. Using distortion analyzer, measure output voltage. Voltage should be less than 1.5 mv.
5. Set SELECTOR switch to TUNER.
6. Insert shorting plugs in TUNER jacks.
7. Measure output voltage. Voltage should be less than  $60\mu v$ .
8. Set bandpass switch to OUT.

### D. Maximum Output

1. Set selector switch to AUX 1.
2. Connect AUDIO OSCILLATOR to AUX 1 input jacks.
3. Set oscillator frequency to 1 KHz  $\pm 20$  Hz.
4. Adjust oscillator output until just before oscilloscope indicates clipping.
5. Measure output voltage. Voltage must be greater than 8V.

### E. Balance

1. Reduce oscillator output until distortion analyzer voltmeter indicates 0 dB on channel A.
2. Measure channel B output. Voltage should be 0 dB  $\pm 2$  dB.

NOTE: Adjust for as close a balance as possible for the remaining tests.

### F. Frequency Response

1. Tape Head
  - a. Set SELECTOR switch to TAPE HEAD.
  - b. Connect oscillator to TAPE HEAD input jacks.
  - c. Set oscillator frequency to 500 Hz.
  - d. Adjust oscillator level for 0 dB output at distortion analyzer.
  - e. Set oscillator frequency to 50 Hz. Analyzer should indicate +17.5 dB  $\pm 1$  dB, Figure 6.
  - f. Set oscillator frequency to 10 KHz. Analyzer should indicate -15.5 dB  $\pm 1$  dB, Figure 6.

### 2. Phono

- a. Set SELECTOR switch to PHONO 1.
- b. Connect oscillator to PHONO 1 input jacks.
- c. Set oscillator frequency to 1 KHz.
- d. Adjust oscillator level for 0 dB at distortion analyzer.
- e. Set oscillator for 30 Hz. Analyzer should indicate +18.61 dB  $\pm 1$  dB, Figure 6.
- f. Set oscillator for 15 KHz. Analyzer should indicate -17.17 dB  $\pm 1$  dB, Figure 6.

### 3. High Level

- a. Set SELECTOR switch to AUX 1.
- b. Connect oscillator to AUX 1 input jacks and set frequency to 1 KHz.
- c. Adjust oscillator level until analyzer indicates 0 dB.
- d. Set oscillator for 20 Hz. Analyzer should indicate 0 dB +0, -0.25 dB
- e. Set oscillator for 20 KHz. Analyzer should indicate 0 dB +0, -0.25 dB
- f. Set oscillator for 60 KHz. Analyzer should indicate 0 dB +0, -0.25 dB

### 4. Low Filter

- a. Set oscillator to 50 Hz.
- b. Set LOW filter switch to 50. Analyzer should indicate -3 dB  $\pm 1.5$  dB.
- c. Set oscillator to 100 Hz.
- d. Set LOW filter switch to 100. Analyzer should indicate -3 dB  $\pm 1.5$  dB.
- e. Set LOW filter switch to OUT.

### 5. High Filter

- a. Set oscillator to 5 KHz.
- b. Set HIGH filter switch to 5K. Analyzer should indicate -3 dB  $\pm 1.5$  dB.
- c. Set oscillator to 10 KHz.
- d. Set HIGH filter switch to 9K. Analyzer should indicate -5 dB  $\pm 1.5$  dB.
- e. Set HIGH filter switch to OUT.

## 6. Tone Controls

- a. Set oscillator to 1 KHz. Ensure tone control pots are in center position and analyzer indicates 0 dB.
- b. Adjust tone control pots to maximum boost (upper position).
- c. Set oscillator to 100 Hz. Analyzer should indicate  $+10 \text{ dB} \pm 2 \text{ dB}$ .
- d. Set oscillator to 10 KHz. Analyzer should indicate  $+10 \text{ dB} \pm 2 \text{ dB}$ .
- e. Adjust tone control pots to maximum cut (lower position).
- f. Analyzer should indicate  $-10 \text{ dB} \pm 2 \text{ dB}$ .
- g. Set oscillator to 100 Hz. Analyzer should indicate  $-10 \text{ dB} \pm 2 \text{ dB}$ .
- h. Adjust tone control pots to mechanical center.
- i. Set oscillator to 1 KHz. Analyzer should indicate 0 dB.
- j. Set TONE CONTROL switch to OUT. Analyzer should indicate  $0 \text{ dB} \pm 1 \text{ dB}$ .

## 7. Loudness

- a. Set oscillator to 100 Hz. Set TONE CONTROL switch to IN.
- b. Adjust oscillator level for 0 dB at analyzer.

- c. Set VOLUME control to minimum. Set TONE CONTROL switch to LOUDNESS.
- d. Adjust volume control for an indication on analyzer of -20 dB.
- e. Set oscillator to 10 KHz. Analyzer should indicate  $-20 \text{ dB} \pm 2 \text{ dB}$ .
- f. Set oscillator to 1 KHz. Analyzer should indicate  $-27 \text{ dB} \pm 2 \text{ dB}$ .
- g. Set TONE CONTROL switch to IN. Set VOLUME control to maximum.

## G. Harmonic Distortion

1. Set oscillator to 20 Hz.
2. Adjust oscillator level for 3V on both channels. (Adjust BALANCE control if necessary.)
3. Set analyzer to SET LEVEL - MANUAL.
4. Adjust sensitivity vernier for full scale deflection (0-1 scale).
5. Set analyzer to DISTORTION. Analyzer should indicate less than 0.01%.
6. Set oscillator to 20 KHz.
7. Repeat steps 3 through 5.
8. Analyzer should indicate less than 0.01%.

NOTE: Adjust R127 as necessary to meet 20 KHz spec.

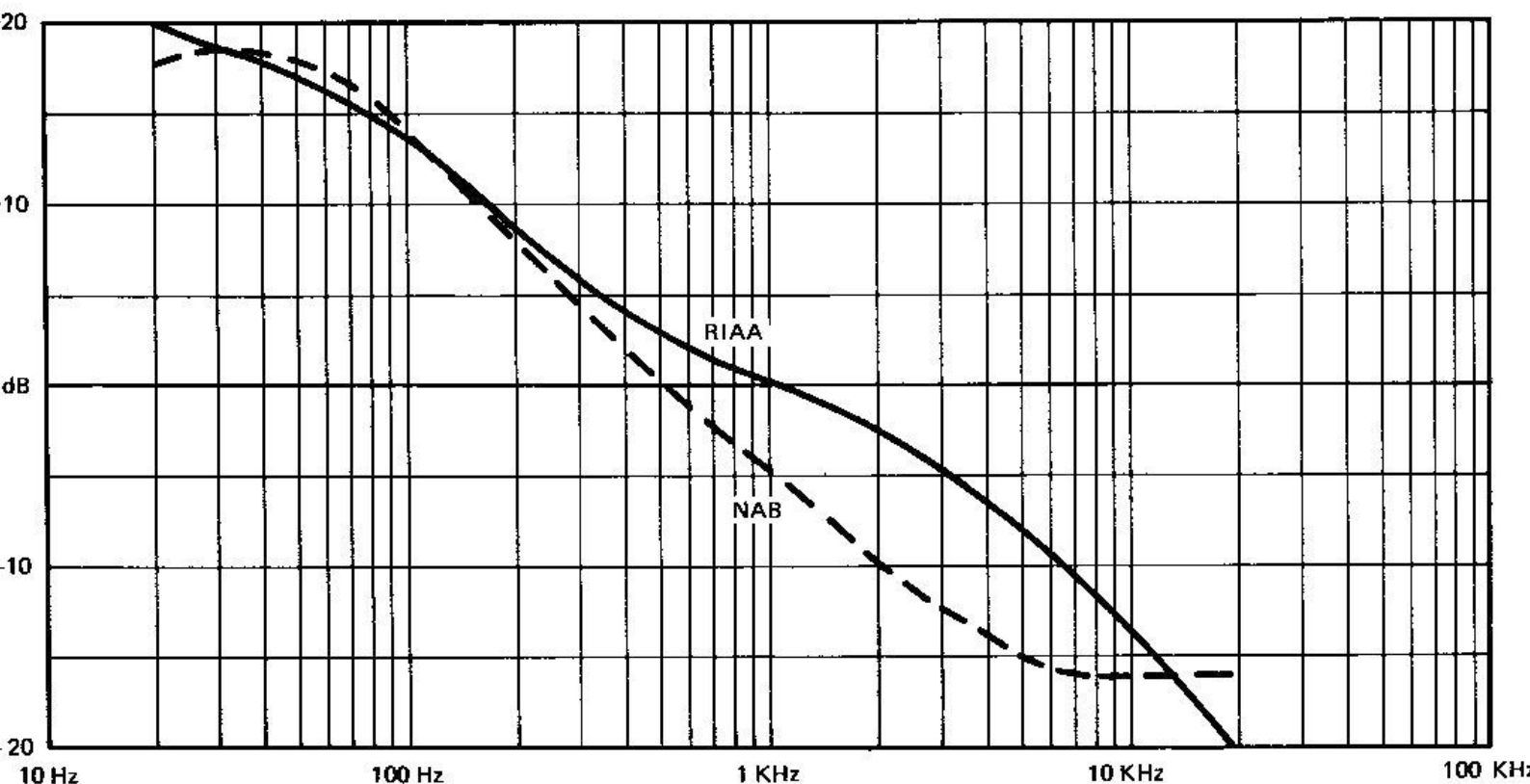

Figure 6. NAB and RIAA Equalization Curves

# TROUBLE ANALYSIS

The trouble analysis procedure that follows contains typical trouble symptoms and their remedies. Other field problems will be covered through service bulletins (supplementary to this manual) which will be issued to all stations. The schematic diagrams (Figures 9, 11, and 13) contain typical voltages taken at various test points in a properly operating amplifier.

NOTE: Performance Verification is necessary following any repair.

## SYMPTOM

## PROCEDURE

1. Excessive Line Consumption
  - a. Check for shorted rectifier CR301 through CR304
  - b. Check capacitors C301, C302, C305, C306
  - c. Check for shorted transistors Q301, Q302, Q303, Q305 through Q309, Q311, Q312. Check for open Q304 and Q310
  - d. Check for shorted T1
2. No Line Consumption
  - a. Check line cord, fuse
  - b. Check for open transistors Q301, Q302, Q303, Q305 through Q309, Q311, Q312. Check for shorted Q304, Q310.
  - c. Check for open rectifiers CR301 through CR304
  - d. Check for open T1
3. High Hum and Noise Level
  - a. Check filter capacitors C301, C302, C304, C305, C306, C308
4. High Distortion or Improper Clipping
  - a. Check FET's Q106, Q109
  - b. Check setting of DC OFFSET ADJUST potentiometer R127

# PARTS LIST

Reference Designator	Description	Marantz Part Number
A1	Pre-Amp Bd Comp Assy	200-1015-1
A2*	Pre-Amp Bd Comp Assy	200-1015-3
A3	Filter/Ctr Chan Comp Assy	200-1016-1
A4	Pwr Supply Bd Comp Assy	200-1010-1
C1	Cap. 0.01 mfd, 1400V	383-1006
C101	Cap. Elect. 10 mfd, 16V	381-1015
C102	Cap. 3600 pfd, 10%, 300V	385-1021
C103	Cap. 1600 pfd, 10%, 300V	385-1020
C104	Cap. 0.01 mfd, 10%, 100V	385-1032
C105	Cap. 680 pfd., 5%, 300V	385-1003
C106*	Cap. Elect. 16 mfd, 10V	381-1004
C107	Cap. Elect. 10 mfd, 16V	381-1011
C108	Cap. 0.005 mfd, 20%, 100V	383-1004
C109	Cap. 1 mfd, 20%, 250V	386-1008
C110	Cap. Elect. 10 mfd, 16V	381-1015
C111	Cap. 0.03 mfd, 20%, 100V	383-1002
C112	Cap. Elect. 10 mfd, 16V	381-1011
C113	Cap. 0.1 mfd, 10%, 250V	386-1000
C114	Cap. 680 pfd, 5%, 300V	385-1003
C115	Cap. 0.03 mfd, 20%, 100V	383-1002
C116	Cap. 100 pfd, 10%, 500V	385-1001
C117	Cap. Elect. 100 mfd, 6.4V	381-1006
C118	Cap. 0.001 mfd, 10%, 100V	385-1023
C119	Cap. Elect. 10 mfd, 16V	381-1015
C120	Cap. 0.01 mfd, 10%, 100V	385-1032
C121	Cap. Elect. 10 mfd, 16V	381-1015
C122	Cap. 0.01 mfd, 10%, 100V	385-1032
C123	Cap. 1000 pfd, 10%, 500V	385-1007
C124	Cap. Elect. 10 mfd, 16V	381-1011
C125	Cap. 680 pfd, 5%, 300V	385-1003
C126	Cap. 0.001 mfd, 10%, 100V	385-1023
C127	Cap. Elect. 2.2 mfd, 35V	381-1023
C128	Cap. Elect. 1 mfd, 25V	381-1017
C129	Cap. Elect. 32 mfd, 10V	381-1016
C130	Cap. Elect. 10 mfd, 16V	381-1011
C131	Cap. Elect. 32 mfd, 10V	381-1016

Reference Designator	Description	Marantz Part Number
C132	Cap. 39 pfd, 10%, 500V	385-1035
C133	Cap. 150 pfd, 10%, 500V	385-1002
C134	Cap. 150 pfd, 10%, 500V	385-1002
C135	Cap. 270 pfd, 10%, 500V	385-1006
C201	Cap. Elect., 10 mfd, 16V	381-1015
C202	Cap. 0.47 mfd, 10%, 250V	386-1006
C203	Cap. 4700 pfd, 10%, 300V	385-1030
C204	Cap. 1600 pfd, 10%, 300V	385-1020
C205	Cap. Elect. 32 mfd, 20%, 10V	381-1016
C206	Cap. Elect. 10 mfd, 16V	381-1015
C207	Cap. 0.47 mfd, 10%, 250V	386-1006
C208	Cap. 4700 pfd, 10%, 300V	385-1030
C209	Cap. 1600 pfd, 10%, 300V	385-1020
C210	Cap. Elect. 32 mfd, 20%, 10V	381-1016
C211	Cap. Elect. 1 mfd, 25V	381-1017
C212	Cap. 1 mfd, 20%, 250V	386-1008
C213*	Cap. 150 pfd, 10%, 500V	385-1002
C214*	Cap. 150 pfd, 10%, 500V	385-1002
C301	Cap. Elect. 470 mfd, 40V	381-1022
C302	Cap. Elect. 470 mfd, 40V	381-1022
C303	Cap. 0.1 mfd, 10%, 250V	386-1000
C304	Cap. Elect. 680 mfd, 25V	381-1009
C305	Cap. Elect. 470 mfd, 40V	381-1022
C306	Cap. Elect. 470 mfd, 40V	381-1022
C307	Cap. 0.1 mfd, 10%, 250V	386-1000
C308	Cap. Elect. 680 mfd, 25V	381-1009
CR101	Diode, Rectifier	460-1009
CR301	Diode, Rectifier	460-1006
CR302	Diode, Rectifier	460-1006
CR303	Diode, Rectifier	460-1006
CR304	Diode, Rectifier	460-1006
CR305	Diode, Zener	459-1002
CR306	Diode, Zener	459-1002
DS1	Lamp, Miniature Bayonet	482-1003
F1	Fuse, 1/4A, 250V	451-1005
L101	Choke, 0.3 Hy	147-1003

Reference Designator	Description	Marantz Part Number
L201	Choke, 19.6 Hy	147-1004
L202	Choke, 5 Hy	147-1002
L203	Choke, 0.25 Hy	147-1001
L204	Choke, 19.6 Hy	147-1004
L205	Choke, 5 Hy	147-1002
L206	Choke, 0.25 Hy	147-1001
Q101*	Transistor, NPN	462-1020-1
Q102*	Transistor, NPN	462-1020-1
Q103*	Transistor, PNP	461-1013
Q104	Transistor, PNP	461-1006-2
Q105	Transistor, NPN	462-1011-2
Q106*	Not used	463-1000
Q107*	Transistor, NPN	462-1020-2
Q108*	Transistor, NPN	462-1020-2
Q109*	Not used	463-1000
Q110	Transistor, PNP	461-1006-3
Q111	Transistor, PNP	461-1006-2
Q112	Transistor, NPN	462-1011-2
Q113*	Transistor, NPN	462-1020-3
Q114*	Transistor, NPN	462-1020-3
Q115	Transistor, PNP	461-1006-3
Q116	Transistor, PNP	461-1006-2
Q117	Transistor, NPN	462-1011-2
Q118	Transistor, NPN	462-1010-2
Q119	Transistor, PNP ( $H_{FE} > 100$ )	461-1012
Q120	Transistor, NPN	462-1016
Q201	Transistor, NPN	462-1010-2
Q202	Transistor, PNP	461-1006-1
Q203	Transistor, NPN	462-1010-2
Q204	Transistor, PNP	461-1006-1
Q205	Transistor, NPN	462-1010-2
Q206	Transistor, PNP	461-1006-1
Q301	Transistor, FET	463-1001
Q302	Transistor, NPN	462-1011-1
Q303*	Transistor, NPN	462-1019
Q304	Transistor, NPN	462-1011-1

Reference Designator	Description	Marantz Part Number
Q305	Transistor, NPN	462-1011-1
Q306	Transistor, NPN	462-1011-1
Q307	Transistor, FET	463-1000
Q308	Transistor, PNP	461-1006-1
Q309*	Transistor, PNP	461-1014
Q310	Transistor, PNP	461-1006-1
Q311	Transistor, PNP	461-1006-1
Q312	Transistor, PNP	461-1006-1
R1	Res. C/F, 56K, 1/2W, 5%	433-5562
R2	Res. C/F, 56K, 1/2W, 5%	433-5562
R3	Res. C/F, 270K, 1/2W, 5%	433-6272
R4	Res. C/F, 56K, 1/2W, 5%	433-5562
R5	Res. C/F, 56K, 1/2W, 5%	433-5562
R6	Res. C/F, 270K, 1/2W, 5%	433-6272
R7	Res. C/F, 8.2K, 1/4W, 5%	434-4822
R8	Res. C/F, 8.2K, 1/4W, 5%	434-4822
R9	Res. Var., Slide, Dual, 100K	420-1010
R10	Res. Var., Slide, Tandem, 150K	420-1009
R11	Res. C/F, 270K, 1/2W, 5%	433-6272
R12	Res. Var., Tandem, 100K	420-1012
R13	Res. C/F, 270K, 1/2W, 5%	433-6272
R14	Res. C/F, 270K, 1/2W, 5%	433-6272
R15	Res. C/F, 270K, 1/2W, 5%	433-6272
R16	Res. C/F, 270K, 1/2W, 5%	433-6272
R17	Res. C/F, 270K, 1/2W, 5%	433-6272
R18	Res. Var., Slide, 100K	420-1003
R19	Res. Var., Slide, 100K	420-1003
R20	Res. Var., Slide, 100K	420-1003
R21	Res. Var., Slide, 100K	420-1003
R22	Res. Var., 100K, 2W	420-1006
R23	Res. C/F, 3.3K, 1/4W, 5%	434-4332
R24	Res. C/F, 3.3K, 1/4W, 5%	434-4332
R101	Res. C/F, 2.2K, 5%, 1/2W	433-4222
R102*	Res. Prec. 130K, 2% 1/2W	432-6131
R103	Res. C/F, 68K, 5%, 1/4W	434-5682
R104	Res. C/F, 2.2 MEG, 10%, 1/4W	434-7223

Reference Designator	Description	Marantz Part Number
R105	Res. C/F, 4.3K, 5%, 1/4W	434-4432
R106	Res. C/F, 3.9 MEG, 10%, 1/4W	434-7393
R107	Res. C/F, 7.5K, 5%, 1/2W	433-4752
R108	Res. C/F, 27K, 5%, 1/2W	433-5272
R109	Res. C/F, 30 ohm, 5%, 1/2W	433-2302
R110*	Res. C/F, 470 ohm, 5%, 1/2W	433-3472
R111	Res. C/F, 56 ohm, 5%, 1/2W	433-2562
R112	Res. C/F, 1 MEG, 5%, 1/4W	434-7102
R113	Res. C/F, 10K, 5%, 1/2W	433-5102
R114	Res. C/F, 820 ohm, 5%, 1/2W	433-3822
R115	Res. C/F, 15K, 5%, 1/2W	433-5152
R116	Res. C/F, 15K, 5%, 1/2W	433-5152
R117	Res. C/F, 820 ohm, 5%, 1/2W	433-3822
R118	Res. C/F, 100 ohm, 5%, 1/2W	433-3102
R119	Res. C/F, 56 ohm, 5%, 1/2W	433-2562
R120	Res. C/F, 56 ohm, 5%, 1/2W	433-2562
R121	Res. C/F, 220 ohm, 5%, 1/2W	433-3222
R122	Res. C/F, 47 ohm, 5%, 1/2W	433-2472
R123	Res. C/F, 100 ohm, 5%, 1/2W	433-3102
R124	Res. C/F, 2.2K, 5%, 1/2W	433-4222
R125	Res. C/F, 470K, 5%, 1/2W	433-6472
R126*	Not used	
R127*	Not used	
R128	Res. C/F, 100 ohm, 5%, 1/2W	433-3102
R129	Res. C/F, 30 ohm, 5%, 1/4W	434-2302
R130	Res. C/F, 27K, 5%, 1/2W	433-5272
R131	Not used	
R132*	Not used	
R133	Res. C/F, 7.5K, 5%, 1/2W	433-4752
R134	Res. C/F, 15K, 5%, 1/2W	433-5152
R135	Res. C/F, 1.3K, 5%, 1/2W	433-4132
R136	Res. C/F, 56 ohm, 5%, 1/2W	433-2562
R137	Res. C/F, 10K, 5%, 1/2W	433-5102
R138	Res. C/F, 820 ohm, 5%, 1/2W	433-3822
R139	Res. C/F, 15K, 5%, 1/2W	433-5152

Reference Designator	Description	Marantz Part Number
R140	Res. C/F, 100 ohm, 5%, 1/2W	433-3102
R141	Res. C/F, 15K, 5%, 1/2W	433-5152
R142	Res. C/F, 820 ohm, 5%, 1/2W	433-3822
R143	Res. C/F, 56 ohm, 5%, 1/2W	433-2562
R144	Res. C/F, 56 ohm, 5%, 1/2W	433-2562
R145	Res. C/F, 220 ohm, 5%, 1/4W	434-3222
R146	Res. C/F, 30 ohm, 5%, 1/2W	433-2302
R147	Res. C/F, 47 ohm, 5%, 1/2W	433-2472
R148	Res. C/F, 33K, 5%, 1/2W	433-5332
R149	Res. C/F, 7.5K, 5%, 1/2W	433-4752
R150	Res. C/F, 10K, 5%, 1/2W	433-5102
R151	Res. C/F, 7.5K, 5%, 1/2W	433-4752
R152	Res. C/F, 33K, 5%, 1/2W	433-5332
R153	Res. C/F, 27K, 5%, 1/2W	433-5272
R154	Res. C/F, 7.5K, 5%, 1/2W	433-4752
R155	Res. C/F, 30 ohm, 5%, 1/4W	434-2302
R156	Res. C/F, 30 ohm, 5%, 1/2W	433-2302
R157	Res. C/F, 39K, 5%, 1/2W	433-5392
R158	Res. C/F, 56 ohm, 5%, 1/2W	433-2562
R159	Res. C/F, 10K, 5%, 1/2W	433-5102
R160	Res. C/F, 820 ohm, 5%, 1/2W	433-3822
R161	Res. C/F, 15K, 5%, 1/4W	434-5152
R162	Res. C/F, 15K, 5%, 1/4W	434-5152
R163	Res. C/F, 820 ohm, 5%, 1/2W	433-3822
R164	Res. C/F, 56 ohm, 5%, 1/2W	433-2562
R165	Res. C/F, 220 ohm, 5%, 1/4W	434-3222
R166	Res. C/F, 47 ohm, 5%, 1/4W	434-2472
R167	Res. C/F, 56 ohm, 5%, 1/2W	433-2562
R168	Res. C/F, 7.5K, 5%, 1/2W	433-4752
R169	Res. C/F, 47K, 5%, 1/2W	433-5472
R170	Res. C/F, 100K, 5%, 1/2W	433-6102
R171	Res. C/F, 470 ohm, 5%, 1/2W	433-3472
R172	Res. C/F, 56 ohm, 5%, 1/2W	433-2562
R173	Res. C/F, 10K, 5%, 1/2W	433-5102
R174	Res. C/F, 220 ohm, 5%, 1/2W	433-3222



Reference Designator	Description	Marantz Part Number
R175	Not used	
R176	Res. C/F, 100K, 5%, 1/2W	433-6102
R177	Res. C/F, 10K, 5%, 1/2W	433-5102
R178	Res. C/F, 56 ohm, 5%, 1/2W	433-2562
R179*	Value to be determined in test, 5%, 1/2W	433-XXX2
R201	Res. C/F, 6.8K, 5%, 1/4W	434-4682
R202	Res. C/F, 3.3K, 5%, 1/4W	434-4332
R203	Res. C/F, 5.6K, 5%, 1/4W	434-4562
R204	Res. C/F, 10K, 5%, 1/4W	434-5102
R205	Res. C/F, 100K, 5%, 1/2W	433-6102
R206	Res. C/F, 2.7K, 5%, 1/2W	433-4272
R207	Res. C/F, 7.5K, 5%, 1/2W	433-4752
R208	Res. C/F, 56 ohm, 5%, 1/2W	433-2562
R209	Res. C/F, 100 ohm, 5%, 1/2W	433-3102
R210	Res. C/F, 27K, 5%, 1/4W	434-5272
R211	Res. C/F, 6.8K, 5%, 1/4W	434-4682
R212	Res. C/F, 3.3K, 5%, 1/4W	434-4332
R213	Res. C/F, 5.6K, 5%, 1/4W	434-4562
R214	Res. C/F, 10K, 5%, 1/4W	434-5102
R215	Res. C/F, 100K, 5%, 1/2W	433-6102
R216	Res. C/F, 7.5K, 5%, 1/2W	433-4752
R217	Res. C/F, 2.7K, 5%, 1/2W	433-4272
R218	Res. C/F, 56 ohm, 5%, 1/2W	433-2562
R219	Res. C/F, 100 ohm, 5%, 1/2W	433-3102
R220	Res. C/F, 27K, 5%, 1/4W	434-5272
R221	Res. C/F, 100K, 5%, 1/2W	433-6102
R222	Res. C/F, 7.5K, 5%, 1/2W	433-4752
R223	Res. C/F, 1K, 5%, 1/2W	433-4102
R224	Res. C/F, 2.7K, 5%, 1/2W	433-4272
R225	Res. C/F, 56 ohm, 5%, 1/2W	433-2562
R226	Res. C/F, 100 ohm, 5%, 1/2W	433-3102
R227	Res. C/F, 1K, 5%, 1/2W	433-4102
R301	Not used	
R302	Res. C/F, 10K, 1/2W, 5%	433-5102

Reference Designator	Description	Marantz Part Number
R303	Not used	
R304	Res. C/F, 470 ohm, 1/2W, 5%	433-3472
R305	Res. C/F, 1.2K, 1/2W, 5%	433-4122
R306	Res. C/F, 5.6 ohm, 1/2W, 5%	433-1562
R307	Res. C/F, 1.2K, 1/2W, 5%	433-4122
R308	Res. C/F, 820 ohm, 1/2W, 5%	433-3822
R309	Res. Var. 1K, 1/4W	420-1013
R310	Res. C/F, 510 ohm, 1/2W, 5%	433-3512
R311	Not used	
R312	Res. C/F, 4.7K, 1/2W, 5%	433-4472
R313	Not used	
R314	Res. C/F, 470 ohm, 1/2W, 5%	433-3472
R315	Res. C/F, 1.2K, 1/2W, 5%	433-4122
R316	Res. C/F, 5.6 ohm, 1/2W, 5%	433-1562
R317	Res. C/F, 1.2K, 1/2W, 5%	433-4122
R318	Res. C/F, 820 ohm, 1/2W, 5%	433-3822
R319	Res. Var. 1K, 1/4W	420-1013
R320	Res. C/F, 510 ohm, 1/2W, 5%	433-3512
S1	Switch, Rotary (Selector)	453-1000
S2	Switch, Lever (Monitor)	453-1011
S3	Switch, Rotary (Mode)	453-1012
S4	Switch, Lever (Tone)	453-1008
S5	Switch, Lever (Lo Filter)	453-1009
S6	Switch, Lever (Hi Filter)	453-1009
S7	Switch, Snap (Power)	453-1010
T1	Transformer, Power	440-1004
XF1	Fuseholder (W/mtg hole)	367-1001
XQ101*	Socket, Transistor	368-1002
XQ102*	Socket, Transistor	368-1002
	Panel, Front	134-1004-1
	Knob, Large	174-1001
	Knob, Small	174-1004
	Knob, Center Channel	580-1000

\*Denotes a change in some serial numbers. See ECN change record.

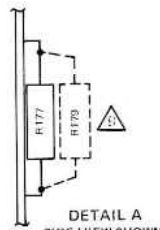
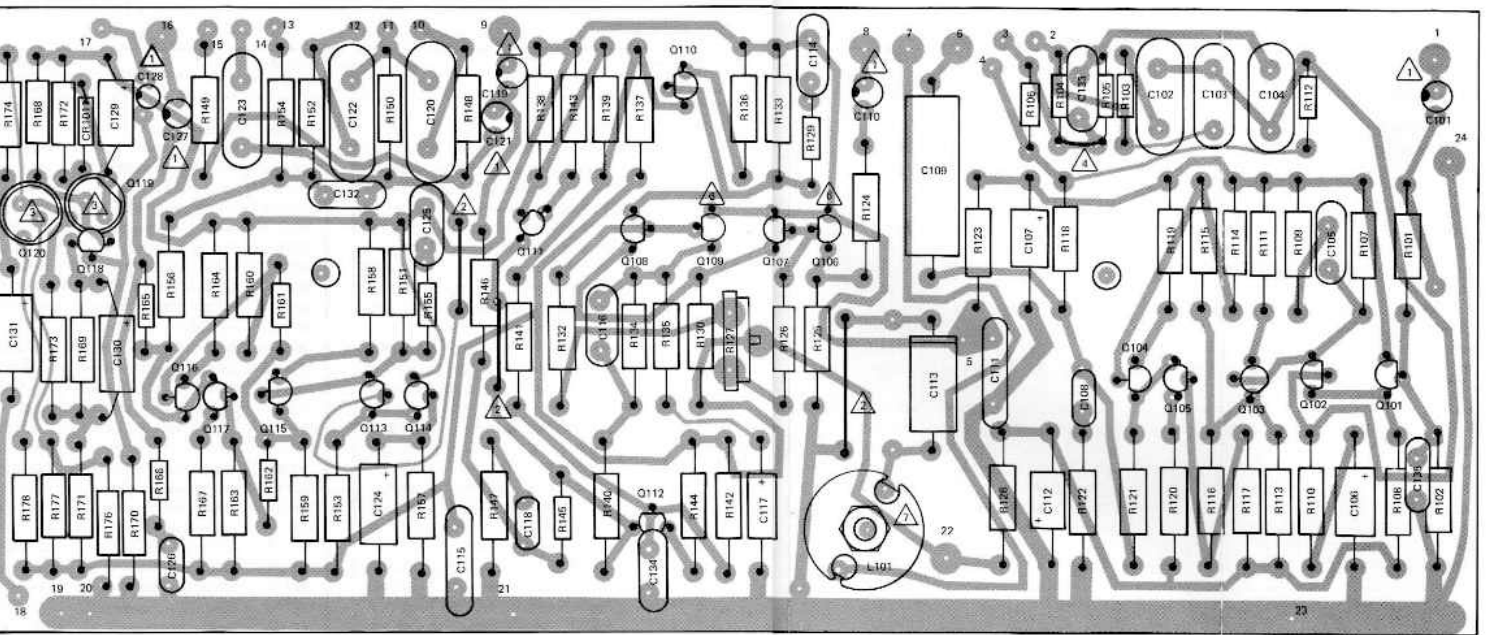
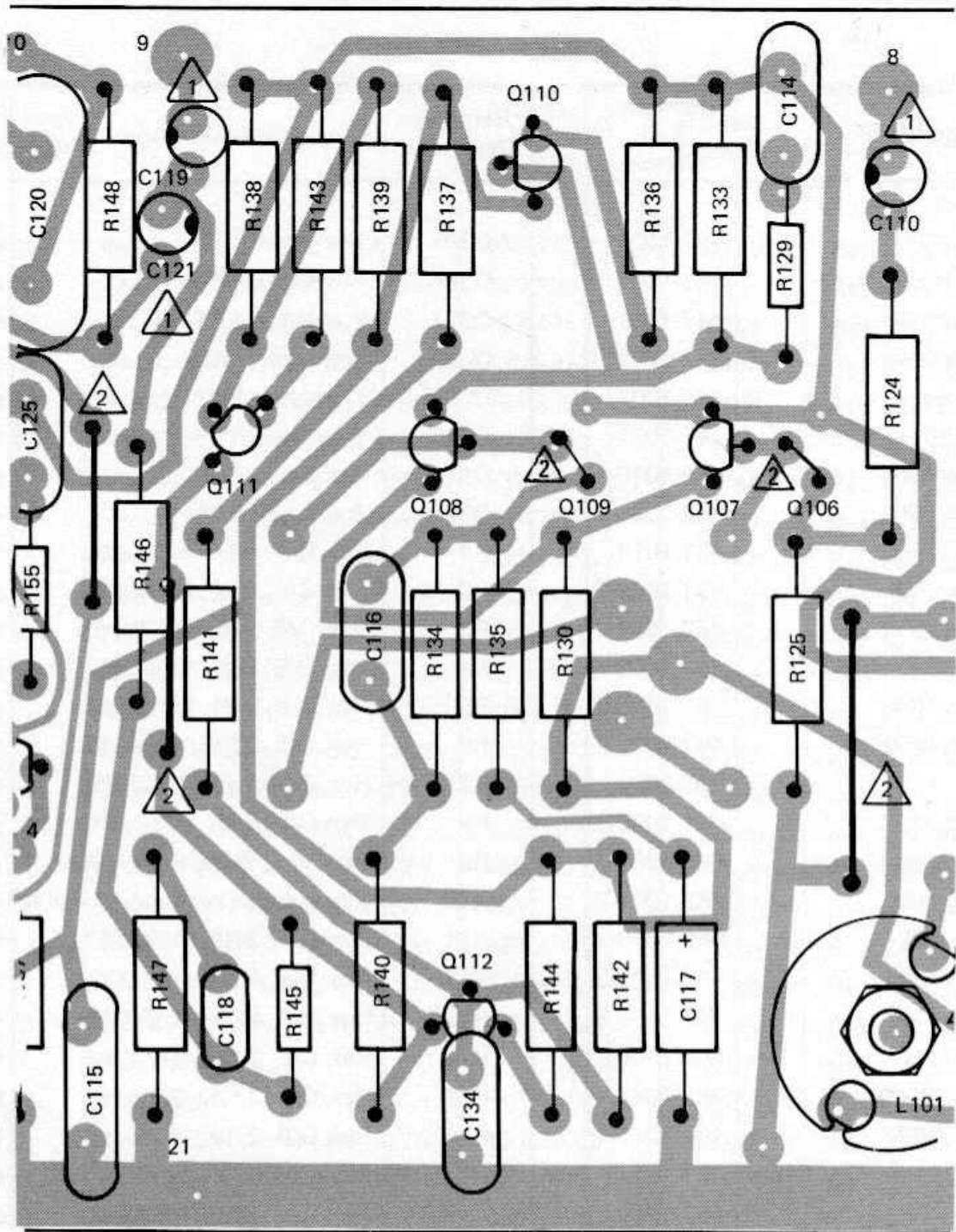

Figure 7. Preamplifier Board Component Assembly Diagram – Revision 1

NOTES: UNLESS OTHERWISE SPECIFIED

- ⚠ Q101, C110, C119, C121, C127 AND C128 POLARIZATION IS DETERMINED BY HOLDING THE COMPONENT WITH THE MULTIPLIER DOT FACING THE VIEWER – IN THIS POSITION THE POSITIVE LEAD IS ON THE RIGHT.
- ⚠ #22 AWG TCI SUS WIRE ON COMPONENT SIDE.
- ⚠ INSULATOR TO BE INSTALLED BETWEEN BOARD AND TRANSISTORS, Q119 AND Q120 ONLY.
- ⚠ SUS WIRE JUMPER BETWEEN R104 AND R105 INSTALLED ONLY ON BOARDS MARKED A/W 115-1014, REV. A.

- ⚠ ASSEMBLY CONFIGURATION SHOWN IS TYPICAL FOR BOARDS FABRICATED FROM A/W 115-1014, REV. A.
- ⚠ Q106 AND Q109 ARE TO BE COLOR MATCHED RANGE.
- ⚠ HEAD OF SCREW TO BE ON CIRCUIT SIDE OF BOARD.
- ⚠ Q101 THRU Q118 ARE TO BE INSTALLED WITH CUTTING TRANSISTOR LEADS.
- ⚠ WHEN REQUIRED, R179 WILL BE SELECTED AT TEST AND MOUNTED AS SHOWN IN DETAIL A.
- ⚠ VALUE OF C106 MAY BE 32 MFD @ 10V WHEN REQUIRED BY TEST.



PARTIAL VIEW – REMAINDER SAME AS REVISION 1

NOTES:

- 1 ASSY 200-1015-3 IS IDENTICAL TO ASSY 200-1015-1 EXCEPT THAT Q101 AND Q102 (AND TRANSISTOR SOCKETS) ARE MOUNTED ON CIRCUIT SIDE OF BOARD.
- 2 ASSY NOTES FOR REVISION 2 ARE THE SAME AS FOR REVISION 1 EXCEPT NOTE 6 IS NOT APPLICABLE.

Figure 8. Preamplifier Board Component Assembly Diagram – Revision 2

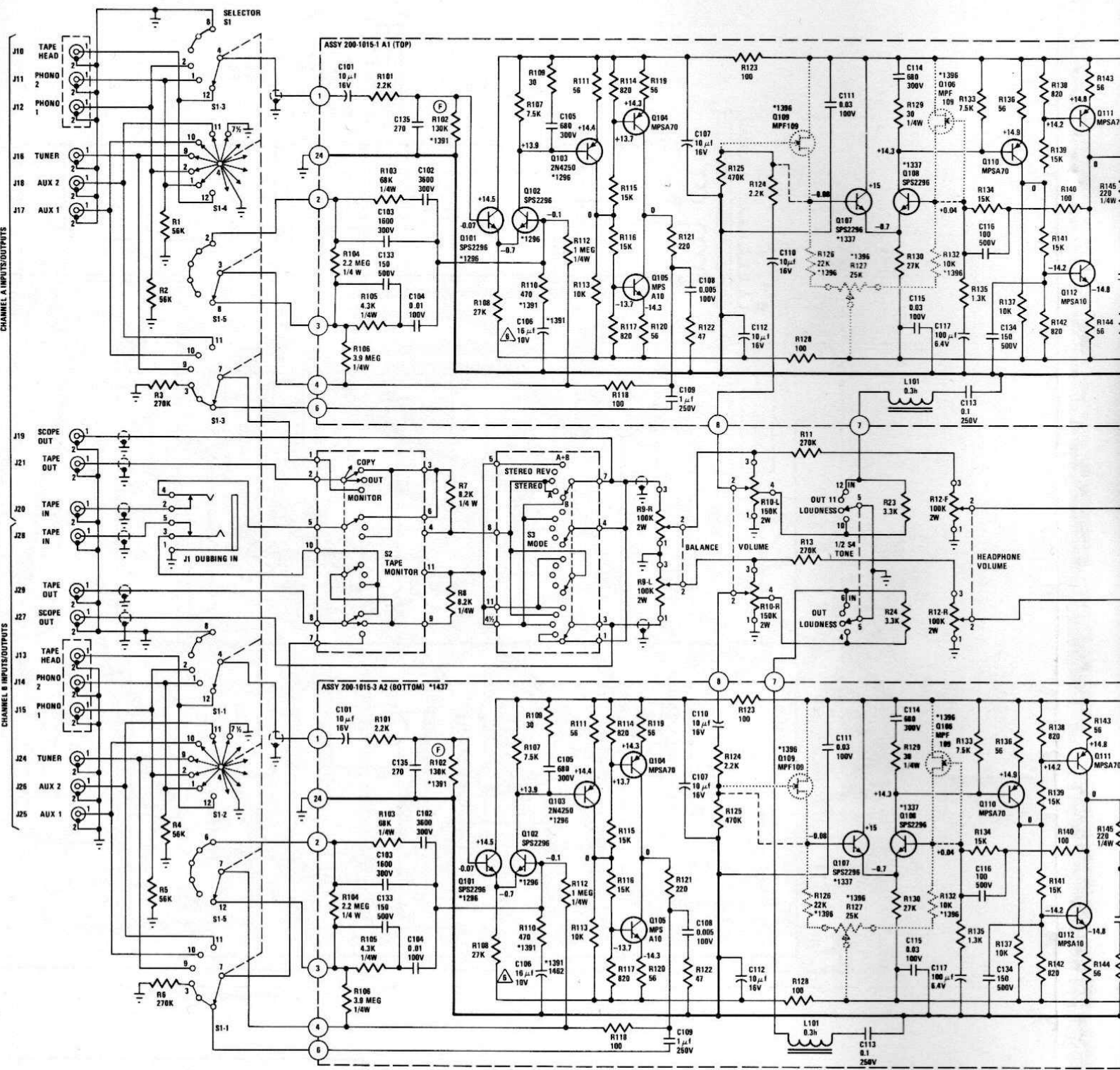

NOTES: UNLESS OTHERWISE SPECIFIED

- ① CIRCUIT COMMON TO REVISIONS 1 AND 2 IS SHOWN IN SOLID LINES. CIRCUITRY AND COMPONENTS DELETED BY ECN 1396 IS SHOWN IN DOTTED ( . . . ) LINES; CIRCUITRY ADDED BY ECN 1396 IS SHOWN IN DASHED ( - - ) LINES.

- ②
- ③
- ④

Figure 9. Preamplifier Circuit and Switching Schematic

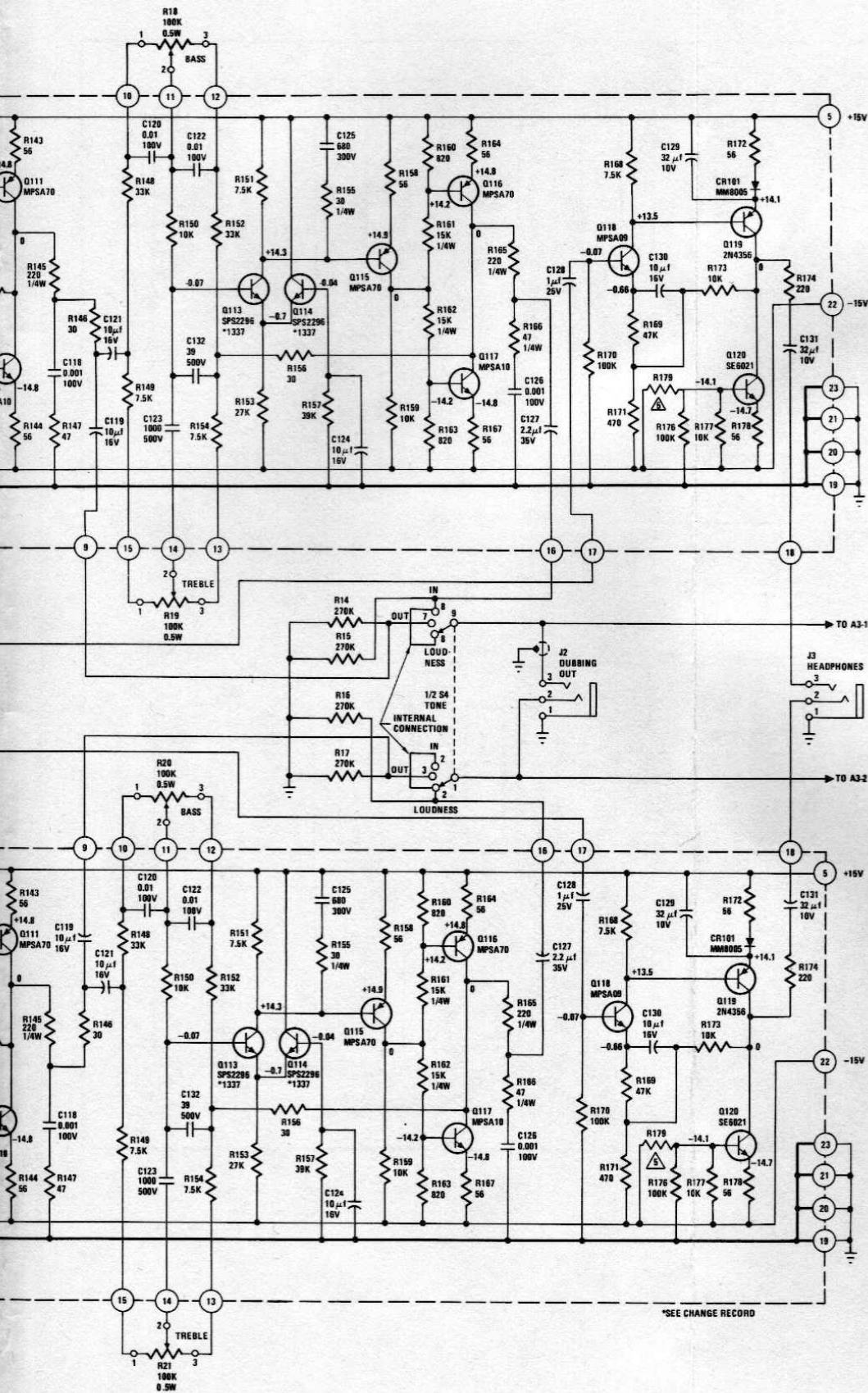

REF. DES.	BETA ( $H_{FE}$ )	NOISE LEVEL (MILLI-VOLTS)
Q101	>400	0.17 OR LESS
Q102	>400	0.17 OR LESS
Q103	>150	
Q104	100-149	
Q105	100-149	
Q107	>400	>0.17<0.2
Q108	>400	>0.17<0.2
Q110	>150	
Q111	100-149	
Q112	100-149	
Q113	200-399	0.2 TO 0.3
Q114	200-399	0.2 TO 0.3
Q115	>150	
Q116	100-149	
Q117	100-149	
Q118	100-149	
Q119	>100	

- 2 ALL RESISTORS ARE 1/2W; VALUES ARE IN OHMS.
- 3 CAPACITOR VALUES EXPRESSED DECIMALLY ARE IN MICRO-FARADS; OTHERS ARE IN PICO-FARADS.
- 4 F DENOTES PRECISION FILM RESISTORS.

- 5 WHEN REQUIRED, RESISTOR R179 WILL BE SELECTED IN TEST AND MOUNTED IN PARALLEL WITH RESISTOR R177.
- 6 VALUE OF C106 MAY BE 32 MFD @ 10V WHEN REQUIRED BY TEST.

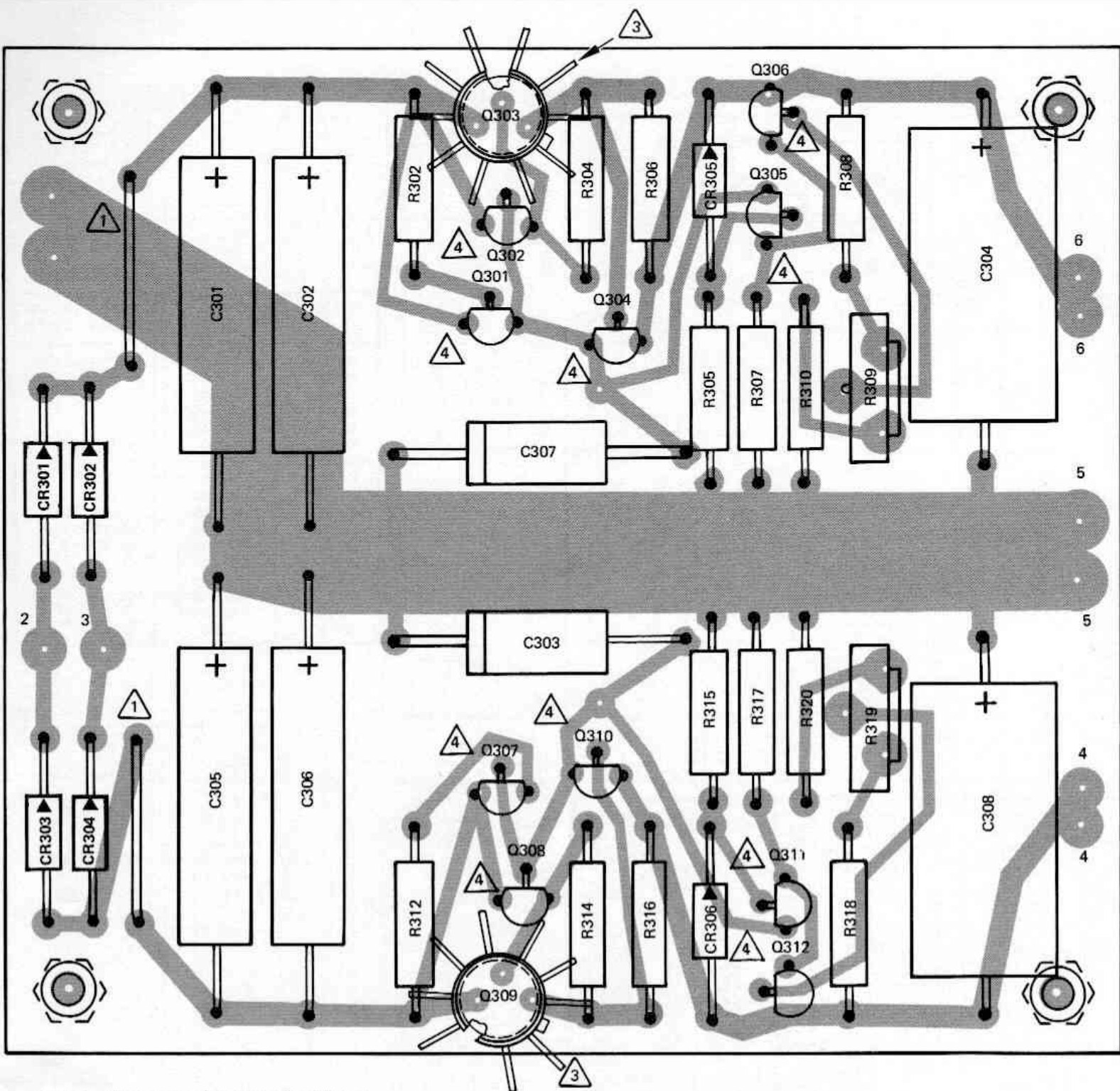

NOTES: UNLESS OTHERWISE SPECIFIED

- ① (22 AWG TC) BUS WIRE
- ② ASSEMBLY CONFIGURATION SHOWN IS TYPICAL FOR BOARDS FABRICATED FROM A/W 115-1010, REV. A.
- ③ HEATSINK ON Q303 AND Q309, SHALL NOT TOUCH THE CASE OF Q302 AND Q308 RESPECTIVELY.
- ④ Q301, Q302, Q304 THRU Q308 AND Q310 THRU Q312 TO BE INSTALLED WITHOUT CUTTING TRANSISTOR LEADS.

Figure 10. Power Supply Board Component Assembly Diagram

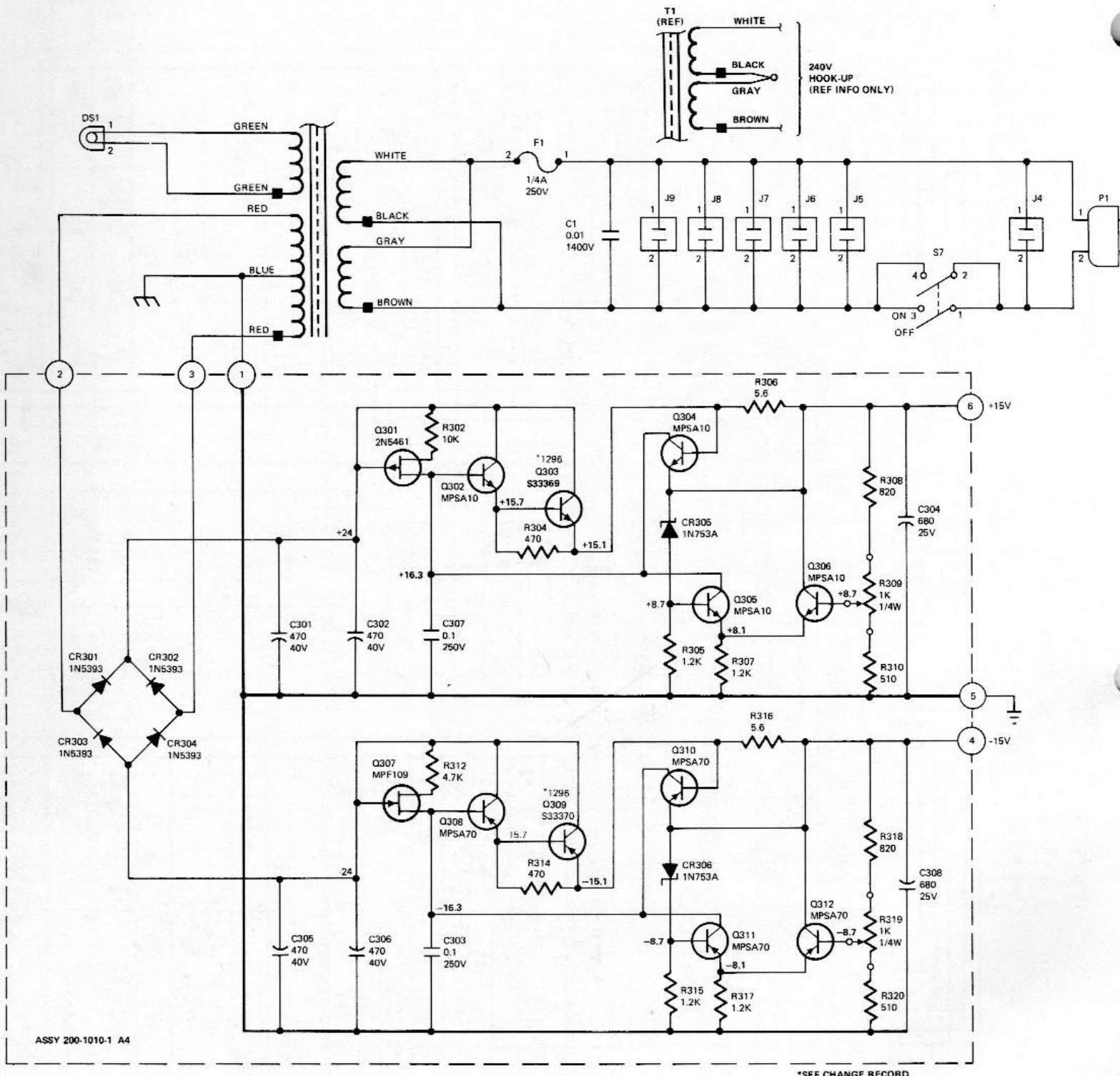

NOTES: UNLESS OTHERWISE SPECIFIED

- ① ALL RESISTORS ARE 1/2W; VALUES ARE IN OHMS.
- ② CAPACITOR VALUES ARE IN MICRO-FARADS.

REF. DES.	BETA (H <sub>FE</sub> )	NOISE LEVEL (MILLI-VOLTS)
Q302	40-99	
Q304	40-99	
Q305	40-99	
Q306	40-99	
Q308	40-99	
Q310	40-99	
Q311	40-99	
Q312	40-99	

Figure 11. Power Supply Circuit Schematic

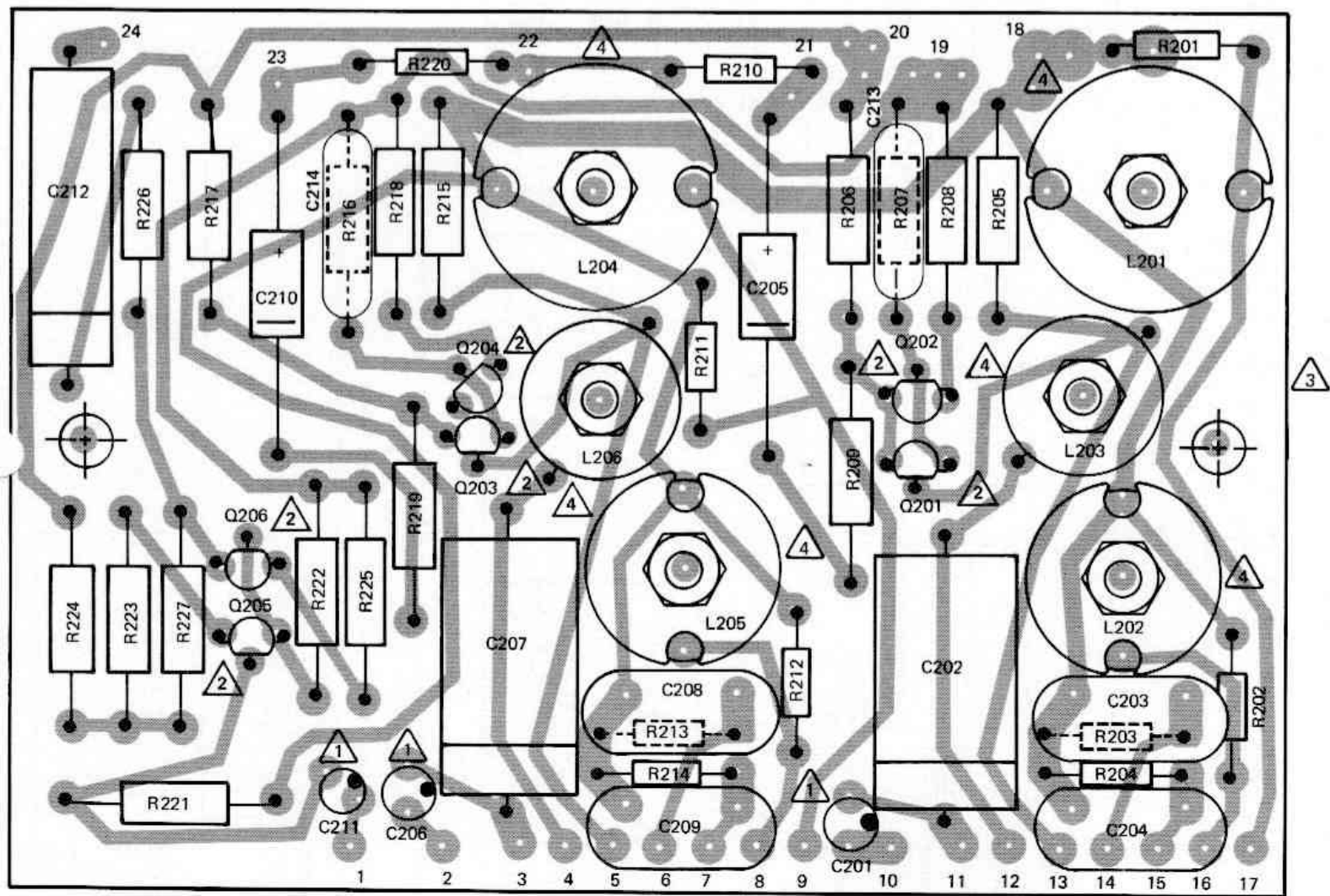

NOTES: UNLESS OTHERWISE SPECIFIED.



POLARITY OF C201, C206 AND C211 IS INDICATED BY HOLDING CAPACITOR WITH COLORED DOT TOWARD VIEWER. POSITIVE LEAD IS ON THE RIGHT.



Q201 THRU Q206 ARE TO BE INSTALLED WITHOUT CUTTING TRANSISTOR LEADS.



ASSEMBLY CONFIGURATION SHOWN IS TYPICAL FOR BOARDS FABRICATED FROM A/W 115-1015, REV. N/C.



HEAD OF SCREW TO BE ON CIRCUIT SIDE OF BOARD.

Figure 12. Filter/Center Channel Component Assembly Schematic



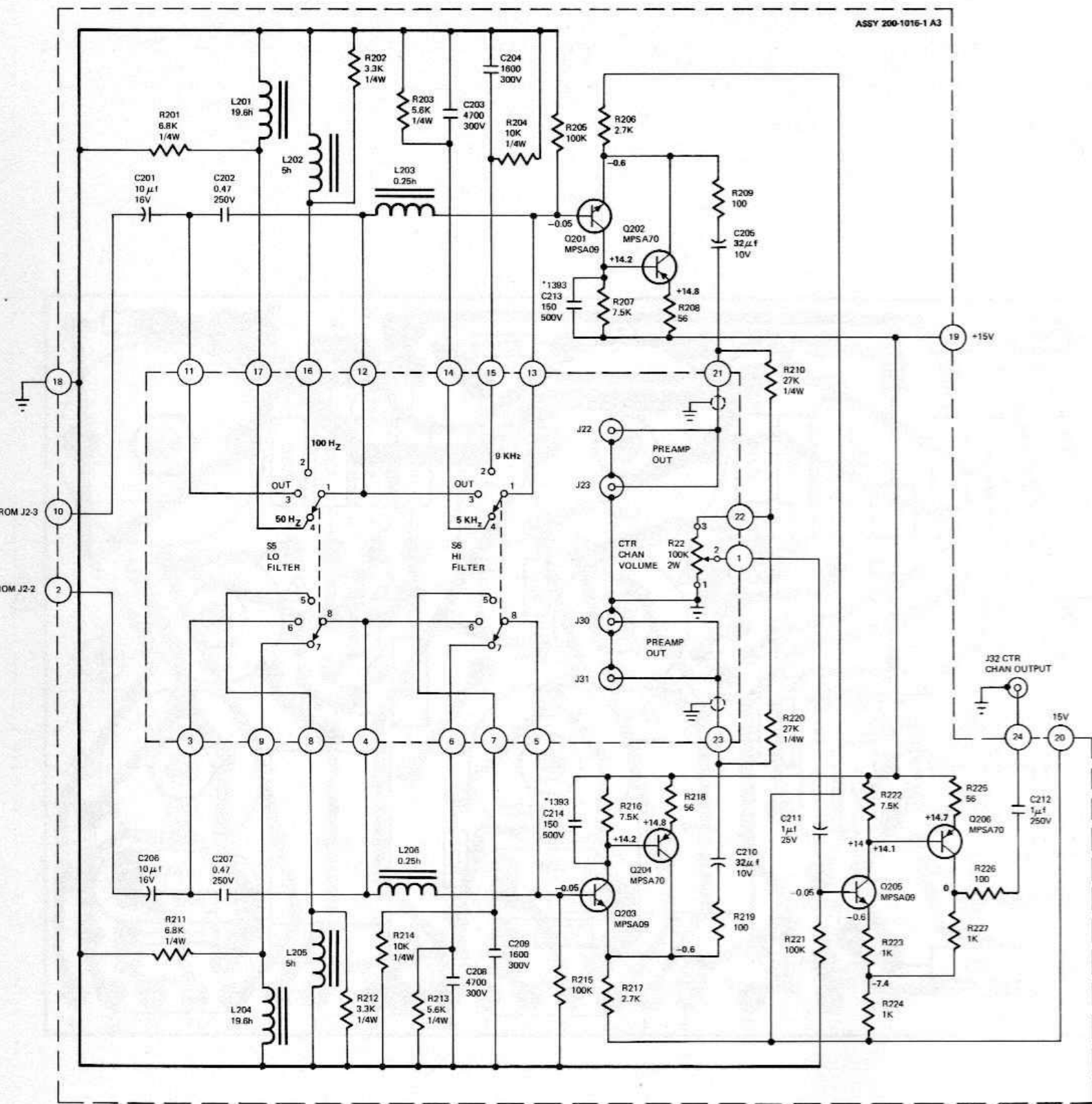

- 1 ALL RESISTORS ARE 1/2W; VALUES ARE IN OHMS.
- 2 CAPACITOR VALUES EXPRESSED DECIMALLY ARE IN MICRO-FARADS; OTHERS ARE IN PICO-FARADS.

REF. DES.	BETA ( $H_{FE}$ )	NOISE LEVEL (MILLI-VOLTS)
Q201	100-149	
Q202	40-99	
Q203	100-149	
Q204	40-99	
Q205	100-149	
Q206	40-99	

Figure 13. Filter/Center Channel Circuit Schematic

**marantz®**

MARANTZ CO., INC. • P.O. BOX 99 • SUN VALLEY, CALIFORNIA • 91352  
A WHOLLY-OWNED SUBSIDIARY OF SUPERSCOPE INC., SUN VALLEY, CALIFORNIA 91352